

JSW THE JAPAN STEEL WORKS, LTD.

<https://www.jsw.co.jp/en/>

Division Gate City Ohsaki-West Tower, 11-1, Osaki 1-chome, Shinagawa-ku, Tokyo 141-0032, Japan
 Head Quarter: Phone: +81-3-5745-2081 URL https://www.jsw.co.jp/en/product/business/molding_machine/

Japan Steel Works America, Inc.

Head Office: 1251 Avenue of the Americas, Suite 2390, New York, NY 10020, U.S.A.
 Phone: +1-212-490-2630

New Jersey Technical & Distribution Center:
 1881 Route 46, Ledgewood, NJ 07852, U.S.A.
 Phone: +1-732-285-1952

California Office: 1890 S Carlos Avenue, Building 15, Unit 6, Ontario, CA 91761, U.S.A.
 Phone: +1-909-740-3808

Georgia Office: 1395 S. Marietta Pkwy, Bldg. 200, Suite 201, Marietta, GA 30067, U.S.A.
 Phone: +1-770-575-0383

Illinois Office: 201 Hansen Court, Suite 121, Wood Dale, IL 60191, U.S.A.
 Phone: +1-630-716-3400

Michigan Office: 24387 Halsted Road Unit B, Farmington Hills, MI 48335, U.S.A.
 Phone: +1-248-536-0288

The Japan Steel Works (Singapore) Pte. Ltd.

17 Gul Lane 629413, Singapore
 Phone: +65-6861-4511

PT. JSW Plastics Machinery Indonesia

Gajah Building Unit AP, Jl.Dr.Saharjo Raya No.111 Tebet,
 Jakarta Selatan 12810, Indonesia
 Phone: +62-21-8370-2536

JSW Plastics Machinery (Philippines) Inc.

Unit 2205, 22nd Floor, Asian Star Building, Asean Drive,
 Filinvest Corporate City, Alabang, Muntinlupa City, 1781, Philippines
 Phone: +63-2-8478-2533

JSW Plastics Machinery (M) SDN. BHD.

D12-3A, Block D12, Pusat Perdagangan Dana 1, Jalan PJU 1A/46, 47301,
 Petaling Jaya, Selangor, Malaysia
 Phone: +60-3-7842-6076

The Japan Steel Works (Thailand) Co., Ltd.

78/6 JST Building 4th Floor, Moo 7 King Kaew Road, Rachatewa, Bangplee,
 Samutprakarn 10540, Thailand
 Phone: +66-2-738-5272

JSW Plastics Machinery Vietnam Ltd.

Hanoi Head Office: Room103, Techno-Center Thang Long Industrial Park, Kim Chung Commune,
 Dong Anh District, Hanoi, Vietnam
 Phone: +84-24-3951-6383

Ho Chi Minh Office: Ground Floor, DC Tower, 111D Ly Chinh Thang, Ward 7, District 3, HCC, Vietnam
 Phone: +84-28-3526-1295

JSW Plastics Machinery (H.K.) Co., Ltd.

Room 907, Corporation Park, 11 On Lai Street, Shatin N.T., Hong Kong
 Phone: +852-2648-0720

JSW Plastics Machinery (Shenzhen) Co., Ltd.

101, Building 6, Nangang 2nd Industrial Park, Songbai Road No.1026,
 Yangguang Community, Xili Street, Nanshan District,
 Shenzhen, Guangdong Province, 518055 P.R.China
 Phone: +86-755-8602-0930

JSW Machinery Trading (Shanghai) Co., Ltd.

301, Metro Plaza, No.555 Loushanguan Road, Changning District,
 Shanghai, 200051, P.R.China
 Phone: +86-21-5206-7031

JSW Plastics Machinery (Taiwan) Corp.

Head Office: 1F, No.21, Dahu 1st Road, Gueishan Dist., Taoyuan City, 33373, Taiwan, R.O.C.
 Phone: +886-3-396-2102

Tainan Office: No.69, Dongciaio 6th St., Yongkang Dist., Tainan City, 710038, Taiwan, R.O.C.
 Phone: +886-6-311-4192

Japan Steel Works India Private Limited

611, Time Tower, MG Road, Sector 28, Gurgaon, Haryana, 122001, India
 Phone: +91-124-469-4444

JSW Plastics Machinery Mexico S. de R.L. de C.V.

Avenida Mineral de Valenciana 202 A-1, Parque Industrial Santa Fe,
 Silao, De La Victoria, Guanajuato C.P: 36275, Mexico
 Phone: +52-472-748-9412

JADS SERIES

All Electric Servo Drive
 Injection Molding Machine

- J550ADS J1000ADS
- J650ADS J1300ADS
- J850ADS J1400ADS
- J850ADSW

Specifications

Made in HIROSHIMA

JSW



JQA-QMA13993
 JQA-EM6416 (Hiroshima Plant)

Performance Table

Equipment Dimensions and Mold Related Dimensions

Unit	Item	Model	J550ADS								
			1400H			2300H			3100H		
Injection Unit	Screw diameter	mm	66	76	84	76	84	92	84	92	100
	Screw stroke	mm	300			420			460		
	Theoretical injection capacity	cm ³	1026	1361	1663	1905	2328	2792	2549	3058	3613
	Injection capacity (GP-PS)	g	934	1238	1513	1734	2118	2541	2320	2783	3288
	Injection capacity (PP)	g	749	993	1214	1391	1699	2038	1861	2232	2637
	Injection pressure (Max.)	MPa(kgf/cm ²)	241(2450)	182(1850)	149(1510)	195(1980)	190(1930)	158(1610)	192(1950)	185(1880)	156(1590)
	Holding pressure (Max.)	MPa(kgf/cm ²)	216(2200)	163(1660)	134(1360)	176(1790)	171(1740)	142(1440)	173(1760)	167(1700)	140(1420)
	Injection speed	mm/s	160			160			160		
	Injection rate	cm ³ /s	547	726	887	726	887	1064	887	1064	1257
	Plasticizing capacity (GP-PS)	kg/h	237	338	418	370	420	460	490	510	520
	Plasticizing capacity (PP)	kg/h	160	230	290	270	300	310	340	360	370
	Screw speed	min ⁻¹	210			210	205	185	205	185	170
	Nozzle touch force	kN(tf)	45(4.6)			70(7.1)			70(7.1)		
	Nozzle stroke from platen	mm	50								
Type of nozzle		Open nozzle (Tip type)				Open nozzle					
Barrel temperature control		Barrel 5, Nozzle 1									
Heater wattage	kW	27.1			34.1			36.6			
Clamping Unit	Mechanism		Double toggle								
	Clamping force	kN(tf)	5390(550)								
	Daylight opening (Max.)	mm	1800								
	Opening stroke (Max.)	mm	900								
	Mold height	mm	400 ~ 900								
	Dry cycle (Euromap6)	s-mm	2.7 - 700								
	Distance between Tie-bars (H×V)	mm	1020×970								
	Platen size (H×V)	mm	1420×1320								
	Locating ring diameter	mm	150								
	Ejector point		21 points								
Ejector force	kN(tf)	130(13.3)									
Ejector stroke	mm	180									
General	Machine Weight	t	29			31			32		
	Machine Dimensions (L×W×H)	m	8.97×2.52×2.40			8.97×2.52×2.40			9.22×2.52×2.40		

Remarks

- Maximum injection pressure and maximum holding pressure may be restricted due to molding condition.
- The theoretical injection capacity is (cross sectional area of barrel) × (stroke of screw).
- The injection capacity is variable according to the grade of resin, molding conditions and mold.
- The values for plasticizing capacity are based on our standard test conditions.
- PC, HPVC, other engineering plastic, etc., low temperature setting and high speed molding may require a high torque depending on the grade or molding conditions. Please contact us if you plan.

Note

- 1MPa=10.2kgf/cm², 1kN=0.102tf
- Due to continual improvements, specifications are subject to change without notice.
- Actual figures of the specification will vary depending on final machine configuration. Please contact us if you require more specific data.
- Performance specifications are based on theoretical data.

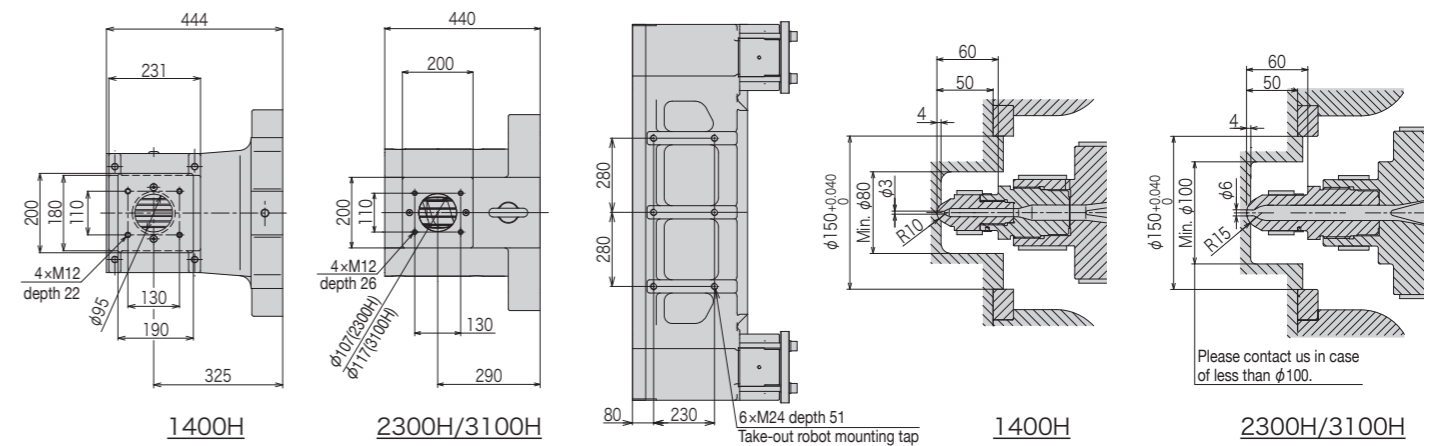
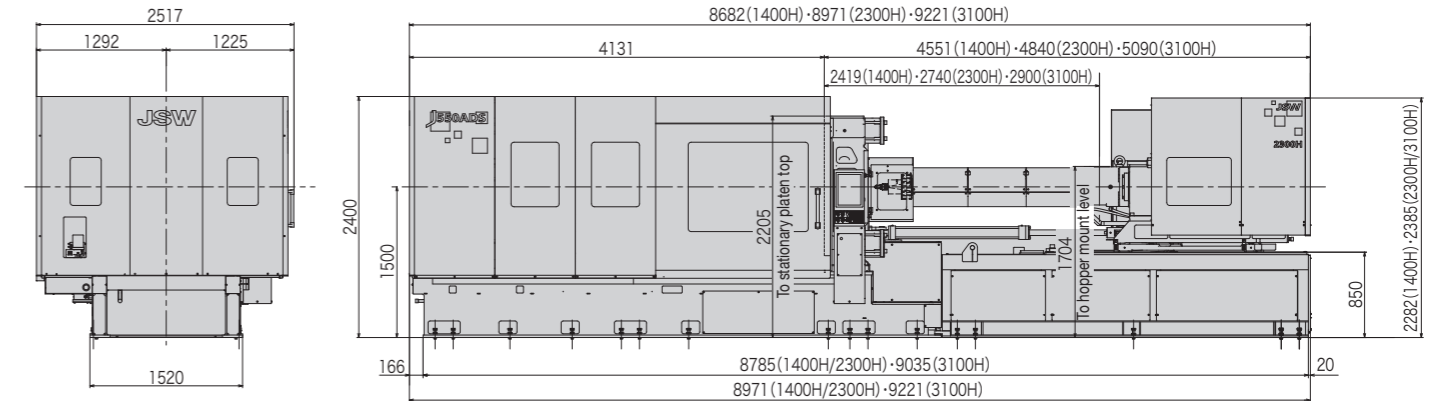

Top of hopper frange

Top of stationary platen

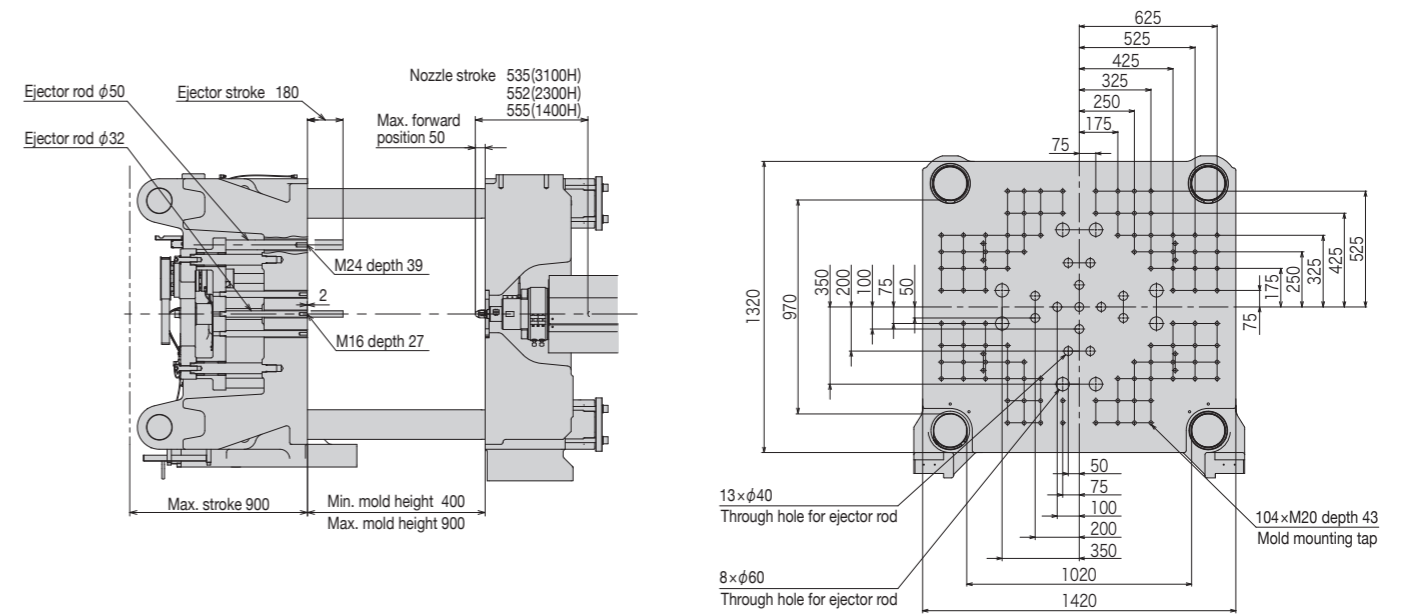

Movable platen

Performance Table

Equipment Dimensions and Mold Related Dimensions

Unit	Item	Model	J650ADS								
			2300H			3100H			3900H		
Injection Unit	Screw diameter	mm	76	84	92	84	92	100	92	100	110
	Screw stroke	mm	420			460			500		
	Theoretical injection capacity	cm ³	1905	2328	2792	2549	3058	3613	3324	3927	4752
	Injection capacity (GP-PS)	g	1734	2118	2541	2320	2783	3288	3025	3574	4324
	Injection capacity (PP)	g	1391	1699	2038	1861	2232	2637	2426	2867	3469
	Injection pressure (Max.)	MPa(kgf/cm ²)	195(1980)	190(1930)	158(1610)	192(1950)	185(1880)	156(1590)	190(1930)	185(1880)	153(1560)
	Holding pressure (Max.)	MPa(kgf/cm ²)	176(1790)	171(1740)	142(1440)	173(1760)	167(1700)	140(1420)	171(1740)	167(1700)	138(1400)
	Injection speed	mm/s	160			160			160		
	Injection rate	cm ³ /s	726	887	1064	887	1064	1257	1064	1257	1521
	Plasticizing capacity (GP-PS)	kg/h	370	420	460	490	510	520	580	610	660
	Plasticizing capacity (PP)	kg/h	270	300	310	340	360	370	410	430	450
	Screw speed	min ⁻¹	210	205	185	205	185	170	185	170	155
	Clamping Unit	Nozzle touch force	kN(tf)	70(7.1)			70(7.1)			70(7.1)	
Nozzle stroke from platen		mm	50								
Type of nozzle			Open nozzle								
Barrel temperature control			Barrel 5, Nozzle 1								
Heater wattage		kW	34.1			36.6			43.3		
Mechanism			Double toggle								
Clamping force		kN(tf)	6370(650)								
Daylight opening (Max.)		mm	2000								
Opening stroke (Max.)		mm	1000								
Mold height		mm	450 ~ 1000								
Dry cycle (Euromap6)	s-mm	2.9 - 800									
Distance between Tie-bars (H×V)	mm	1120 × 1070									
Platen size (H×V)	mm	1550 × 1450									
Locating ring diameter	mm	150									
Ejector point		25 points									
Ejector force	kN(tf)	190(19.4)									
Ejector stroke	mm	200									
General	Machine Weight	t	36			37			39		
	Machine Dimensions (L×W×H)	m	9.35 × 2.65 × 2.40			9.60 × 2.65 × 2.40			10.05 × 2.65 × 2.52		

Remarks

- Maximum injection pressure and maximum holding pressure may be restricted due to molding condition.
- The theoretical injection capacity is (cross sectional area of barrel) × (stroke of screw).
- The injection capacity is variable according to the grade of resin, molding conditions and mold.
- The values for plasticizing capacity are based on our standard test conditions.
- PC, HPVC, other engineering plastic, etc., low temperature setting and high speed molding may require a high torque depending on the grade or molding conditions. Please contact us if you plan.

Note

- 1MPa=10.2kgf/cm², 1kN=0.102tf
- Due to continual improvements, specifications are subject to change without notice.
- Actual figures of the specification will vary depending on final machine configuration. Please contact us if you require more specific data.
- Performance specifications are based on theoretical data.

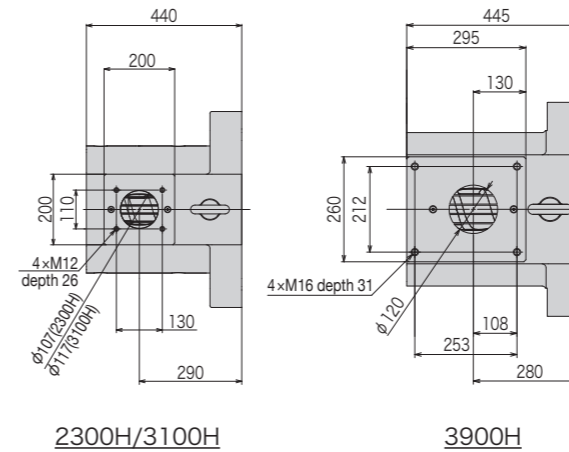
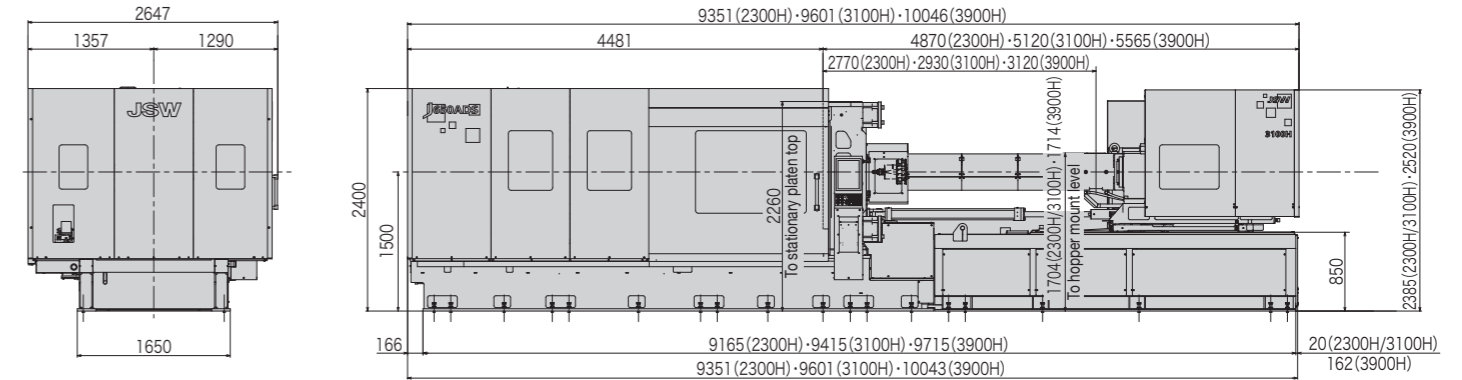

Top of hopper frange

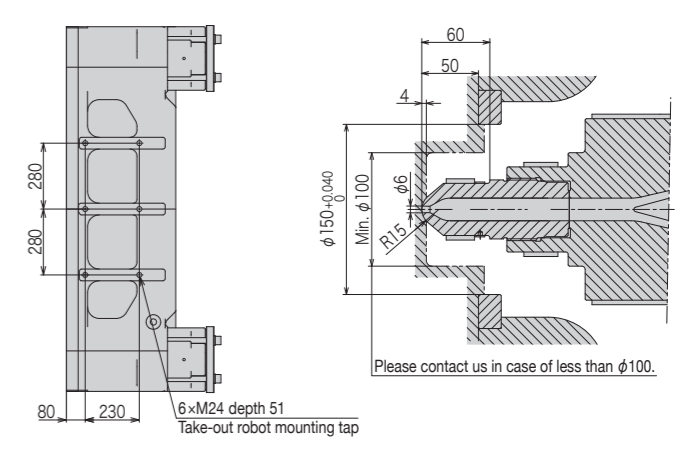

Top of stationary platen

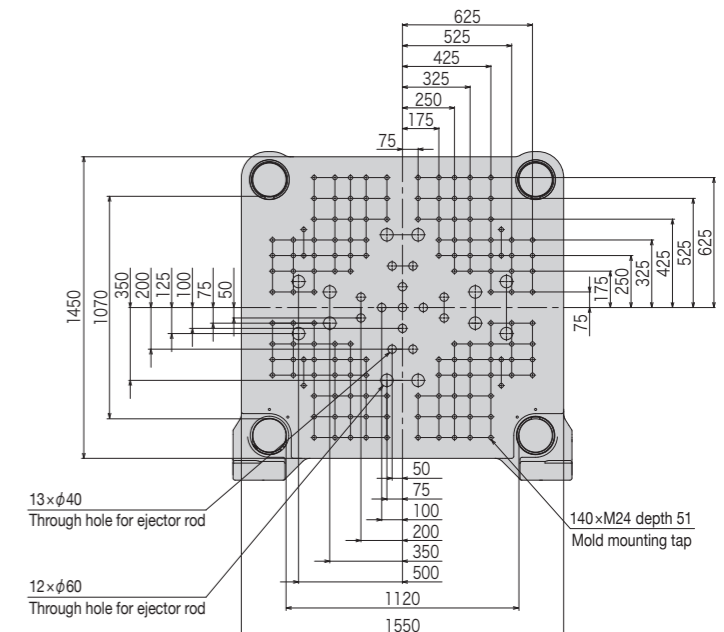
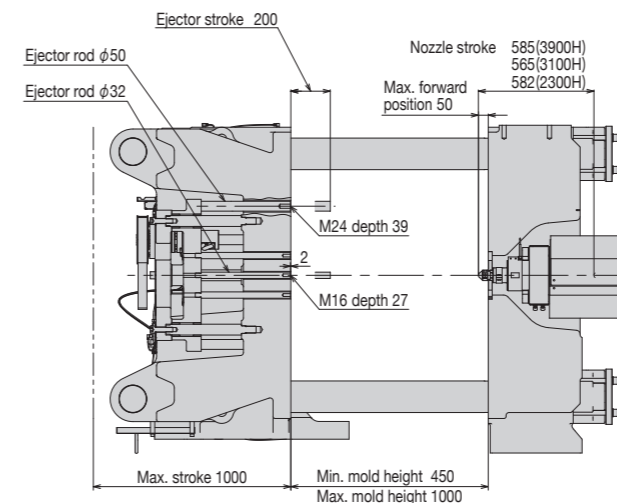

Movable platen

Performance Table

Equipment Dimensions and Mold Related Dimensions

Unit	Item	Model	J850ADS								
			3100H			3900H			5200H		
Injection Unit	Screw diameter	mm	84	92	100	92	100	110	100	110	120
	Screw stroke	mm	460			500			550		
	Theoretical injection capacity	cm ³	2549	3058	3613	3324	3927	4752	4320	5227	6220
	Injection capacity (GP-PS)	g	2320	2783	3288	3025	3574	4324	3931	4756	5661
	Injection capacity (PP)	g	1861	2232	2637	2426	2867	3469	3153	3816	4541
	Injection pressure (Max.)	MPa(kgf/cm ²)	192(1950)	185(1880)	156(1590)	190(1930)	185(1880)	153(1560)	188(1910)	180(1830)	151(1540)
	Holding pressure (Max.)	MPa(kgf/cm ²)	173(1760)	167(1700)	140(1420)	171(1740)	167(1700)	138(1400)	169(1720)	162(1650)	136(1380)
	Injection speed	mm/s	160			160			150		
	Injection rate	cm ³ /s	887	1064	1257	1064	1257	1521	1178	1425	1696
	Plasticizing capacity (GP-PS)	kg/h	490	510	520	580	610	660	660	700	720
	Plasticizing capacity (PP)	kg/h	340	360	370	410	430	450	470	500	520
	Screw speed	min ⁻¹	205	185	170	185	170	155	170	155	145
	Clamping Unit	Nozzle touch force	kN(tf)	70(7.1)			70(7.1)			70(7.1)	
Nozzle stroke from platen		mm	50								
Type of nozzle			Open nozzle								
Barrel temperature control			Barrel 5, Nozzle 1								
Heater wattage		kW	36.6			43.3			52.1		
Mechanism			Double toggle								
Clamping force		kN(tf)	8330(850)								
Daylight opening (Max.)		mm	2300								
Opening stroke (Max.)		mm	1200								
Mold height		mm	500 ~ 1100								
Dry cycle (Euromap6)		s-mm	3.2 - 800								
Distance between Tie-bars (H×V)		mm	1120 × 1070								
Platen size (H×V)		mm	1600 × 1550								
Locating ring diameter	mm	150									
Ejector point		29 points									
Ejector force	kN(tf)	230(23.5)									
Ejector stroke	mm	200									
General	Machine Weight	t	47			49			50		
	Machine Dimensions (L×W×H)	m	10.37 × 2.83 × 2.55			10.81 × 2.83 × 2.55			11.03 × 2.83 × 2.55		

Remarks

- Maximum injection pressure and maximum holding pressure may be restricted due to molding condition.
- The theoretical injection capacity is (cross sectional area of barrel) × (stroke of screw).
- The injection capacity is variable according to the grade of resin, molding conditions and mold.
- The values for plasticizing capacity are based on our standard test conditions.
- PC, HPVC, other engineering plastic, etc., low temperature setting and high speed molding may require a high torque depending on the grade or molding conditions. Please contact us if you plan.

Note

- 1MPa=10.2kgf/cm², 1kN=0.102tf
- Due to continual improvements, specifications are subject to change without notice.
- Actual figures of the specification will vary depending on final machine configuration. Please contact us if you require more specific data.
- Performance specifications are based on theoretical data.

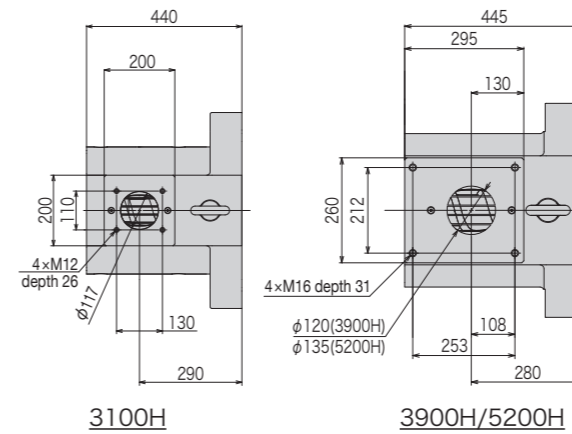
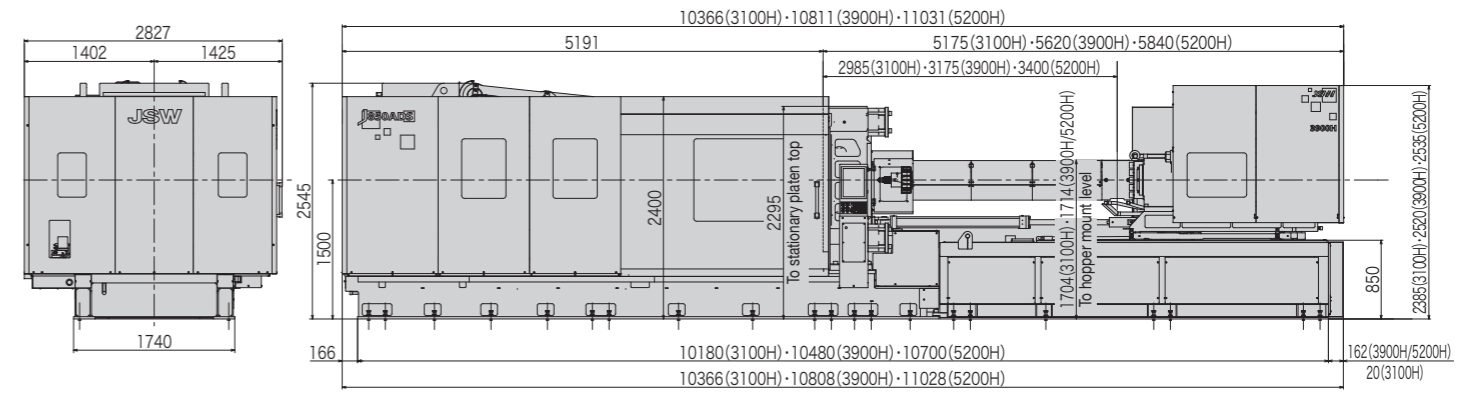

3100H 3900H/5200H

Top of hopper frange

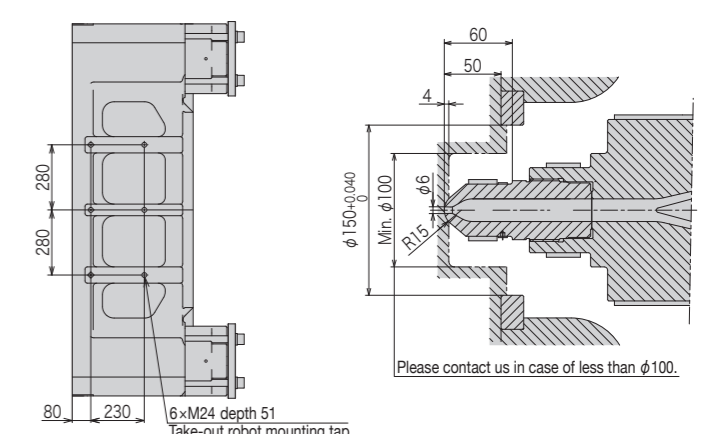

Top of stationary platen

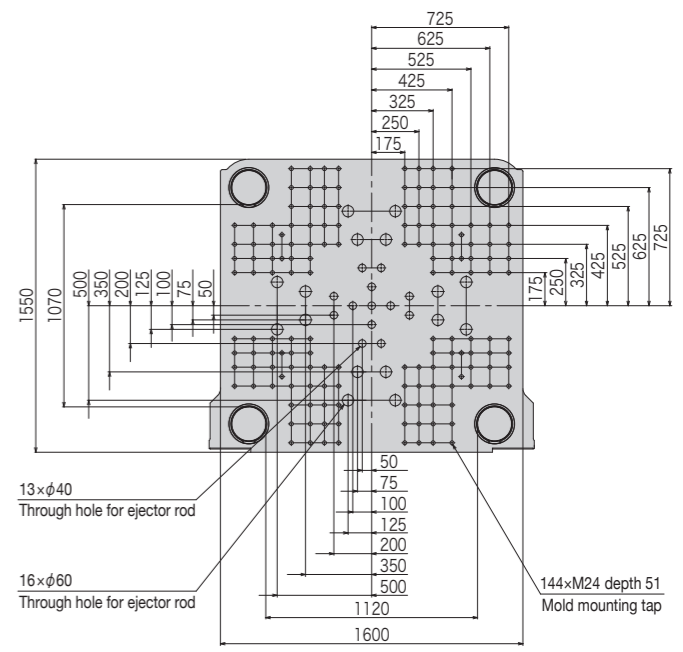
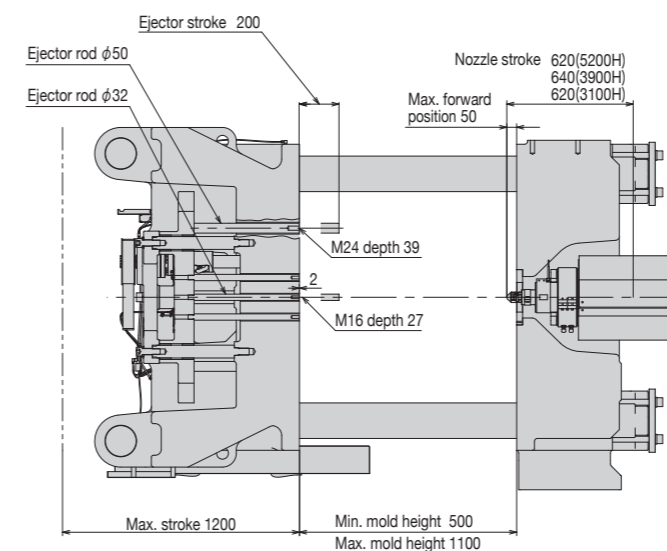

Movable platen

Performance Table

Equipment Dimensions and Mold Related Dimensions

Unit	Item	Model	J850ADSW								
			3100H			3900H			5200H		
Injection Unit	Screw diameter	mm	84	92	100	92	100	110	100	110	120
	Screw stroke	mm	460			500			550		
	Theoretical injection capacity	cm ³	2549	3058	3613	3324	3927	4752	4320	5227	6220
	Injection capacity (GP-PS)	g	2320	2783	3288	3025	3574	4324	3931	4756	5661
	Injection capacity (PP)	g	1861	2232	2637	2426	2867	3469	3153	3816	4541
	Injection pressure (Max.)	MPa(kgf/cm ²)	192(1950)	185(1880)	156(1590)	190(1930)	185(1880)	153(1560)	188(1910)	180(1830)	151(1540)
	Holding pressure (Max.)	MPa(kgf/cm ²)	173(1760)	167(1700)	140(1420)	171(1740)	167(1700)	138(1400)	169(1720)	162(1650)	136(1380)
	Injection speed	mm/s	160			160			150		
	Injection rate	cm ³ /s	887	1064	1257	1064	1257	1521	1178	1425	1696
	Plasticizing capacity (GP-PS)	kg/h	490	510	520	580	610	660	660	700	720
	Plasticizing capacity (PP)	kg/h	340	360	370	410	430	450	470	500	520
	Screw speed	min ⁻¹	205	185	170	185	170	155	170	155	145
	Nozzle touch force	kN(tf)	70(7.1)			70(7.1)			70(7.1)		
	Nozzle stroke from platen	mm	50								
Type of nozzle		Open nozzle									
Barrel temperature control		Barrel 5, Nozzle 1									
Heater wattage	kW	36.6			43.3			52.1			
Clamping Unit	Mechanism		Double toggle								
	Clamping force	kN(tf)	8330(850)								
	Daylight opening (Max.)	mm	2300								
	Opening stroke (Max.)	mm	1200								
	Mold height	mm	500 ~ 1100								
	Dry cycle (Euromap6)	s-mm	3.4 - 950								
	Distance between Tie-bars (H×V)	mm	1370 × 1320								
	Platen size (H×V)	mm	1850 × 1740								
	Locating ring diameter	mm	150								
	Ejector point		29 points								
Ejector force	kN(tf)	230(23.5)									
Ejector stroke	mm	200									
General	Machine Weight	t	52			53			55		
	Machine Dimensions (L×W×H)	m	10.37 × 3.10 × 2.67			10.81 × 3.10 × 2.67			11.03 × 3.10 × 2.67		

Remarks

- Maximum injection pressure and maximum holding pressure may be restricted due to molding condition.
- The theoretical injection capacity is (cross sectional area of barrel) × (stroke of screw).
- The injection capacity is variable according to the grade of resin, molding conditions and mold.
- The values for plasticizing capacity are based on our standard test conditions.
- PC, HPVC, other engineering plastic, etc., low temperature setting and high speed molding may require a high torque depending on the grade or molding conditions. Please contact us if you plan.

Note

- 1MPa=10.2kgf/cm², 1kN=0.102tf
- Due to continual improvements, specifications are subject to change without notice.
- Actual figures of the specification will vary depending on final machine configuration. Please contact us if you require more specific data.
- Performance specifications are based on theoretical data.

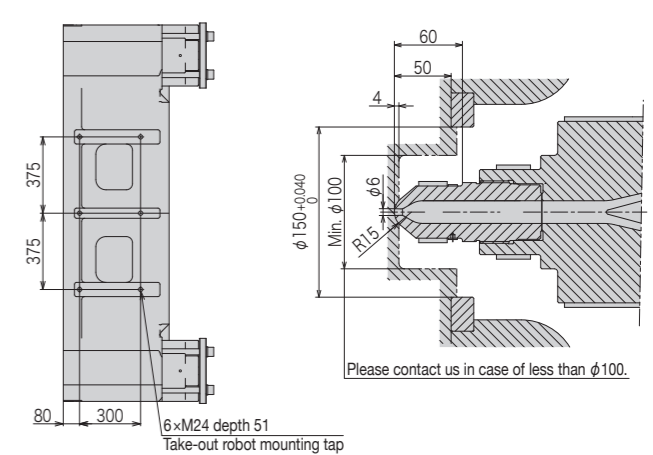
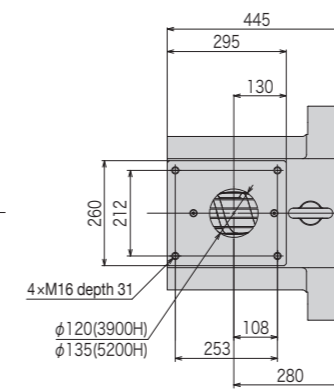
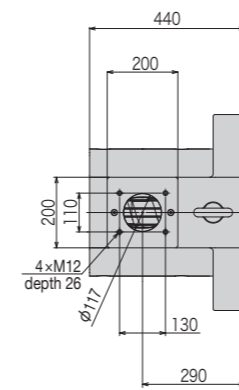
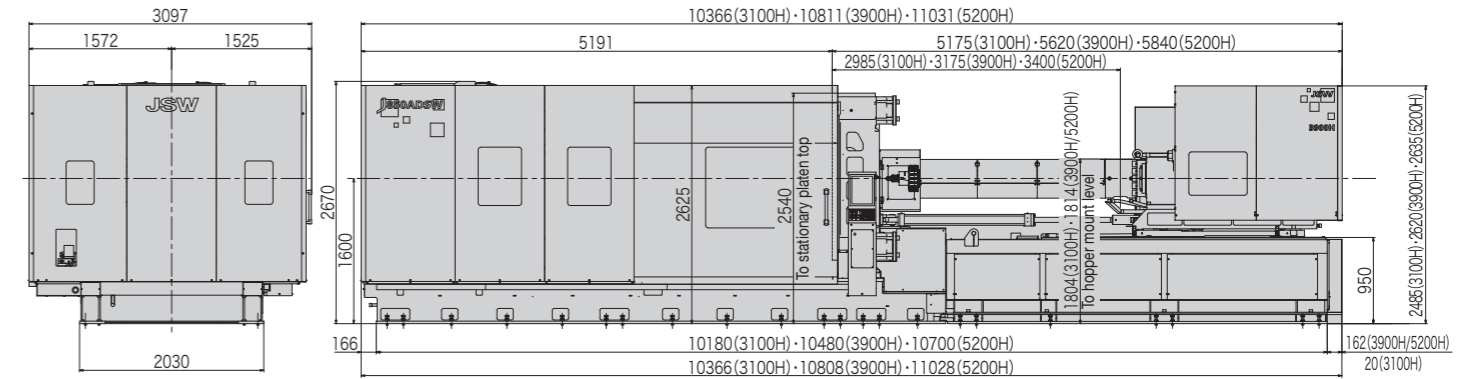

3100H

3900H/5200H

Top of hopper frange

Top of stationary platen

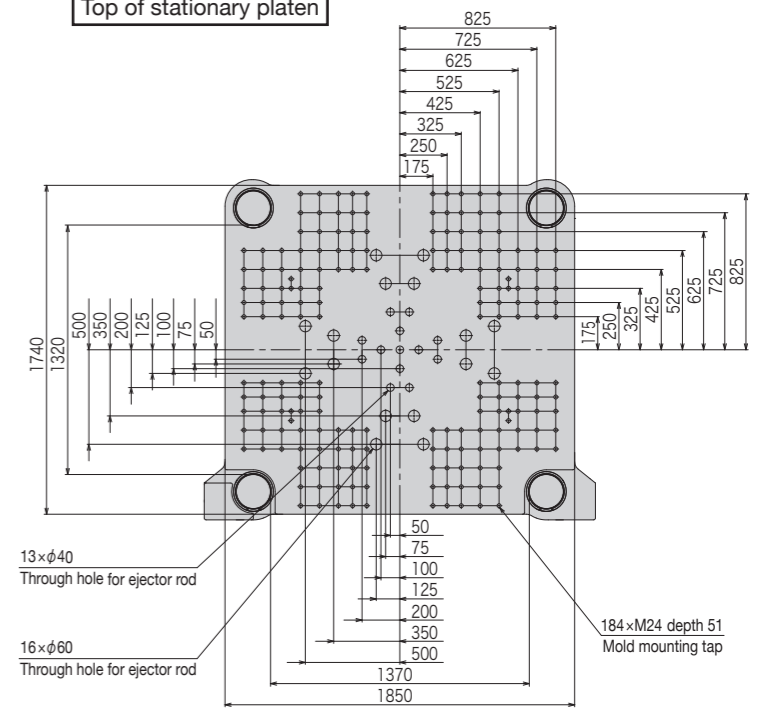
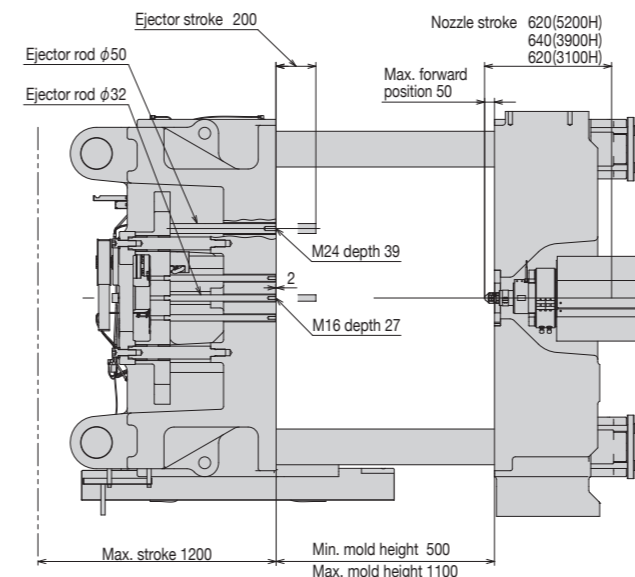

Movable platen

Performance Table

Equipment Dimensions and Mold Related Dimensions

Unit	Item	Model	J1000ADS								
			3100H			3900H			5200H		
Injection Unit	Screw diameter	mm	84	92	100	92	100	110	100	110	120
	Screw stroke	mm	460			500			550		
	Theoretical injection capacity	cm ³	2549	3058	3613	3324	3927	4752	4320	5227	6220
	Injection capacity (GP-PS)	g	2320	2783	3288	3025	3574	4324	3931	4756	5661
	Injection capacity (PP)	g	1861	2232	2637	2426	2867	3469	3153	3816	4541
	Injection pressure (Max.)	MPa(kgf/cm ²)	192(1950)	185(1880)	156(1590)	190(1930)	185(1880)	153(1560)	188(1910)	180(1830)	151(1540)
	Holding pressure (Max.)	MPa(kgf/cm ²)	173(1760)	167(1700)	140(1420)	171(1740)	167(1700)	138(1400)	169(1720)	162(1650)	136(1380)
	Injection speed	mm/s	160			160			150		
	Injection rate	cm ³ /s	887	1064	1257	1064	1257	1521	1178	1425	1696
	Plasticizing capacity (GP-PS)	kg/h	490	510	520	580	610	660	660	700	720
	Plasticizing capacity (PP)	kg/h	340	360	370	410	430	450	470	500	520
	Screw speed	min ⁻¹	205	185	170	185	170	155	170	155	145
	Nozzle touch force	kN(tf)	70(7.1)			70(7.1)			70(7.1)		
	Nozzle stroke from platen	mm	50								
Type of nozzle		Open nozzle									
Barrel temperature control		Barrel 5, Nozzle 1									
Heater wattage	kW	36.6			43.3			52.1			
Clamping Unit	Mechanism		Double toggle								
	Clamping force	kN(tf)	9800(1000)								
	Daylight opening (Max.)	mm	2500								
	Opening stroke (Max.)	mm	1300								
	Mold height	mm	500 ~ 1200								
	Dry cycle (Euromap6)	s-mm	3.9-950								
	Distance between Tie-bars (H×V)	mm	1370 × 1320								
	Platen size (H×V)	mm	1890 × 1780								
	Locating ring diameter	mm	150								
	Ejector point		29 points								
General	Ejector force	kN(tf)	230(23.5)								
	Ejector stroke	mm	200								
General	Machine Weight	t	60			61			63		
	Machine Dimensions (L×W×H)	m	10.84 × 3.18 × 2.76			11.28 × 3.18 × 2.76			11.50 × 3.18 × 2.76		

Remarks

- Maximum injection pressure and maximum holding pressure may be restricted due to molding condition.
- The theoretical injection capacity is (cross sectional area of barrel) × (stroke of screw).
- The injection capacity is variable according to the grade of resin, molding conditions and mold.
- The values for plasticizing capacity are based on our standard test conditions.
- PC, HPVC, other engineering plastic, etc., low temperature setting and high speed molding may require a high torque depending on the grade or molding conditions. Please contact us if you plan.

Note

- 1MPa=10.2kgf/cm², 1kN=0.102tf
- Due to continual improvements, specifications are subject to change without notice.
- Actual figures of the specification will vary depending on final machine configuration. Please contact us if you require more specific data.
- Performance specifications are based on theoretical data.

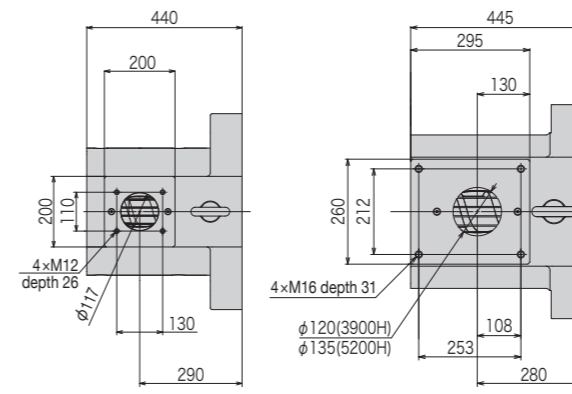
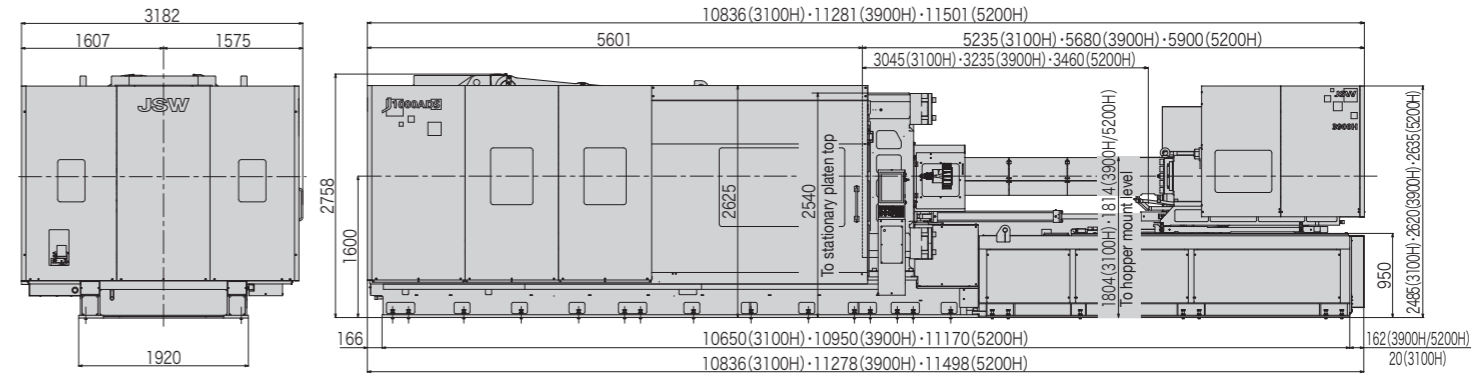

3100H 3900H/5200H

Top of hopper frange

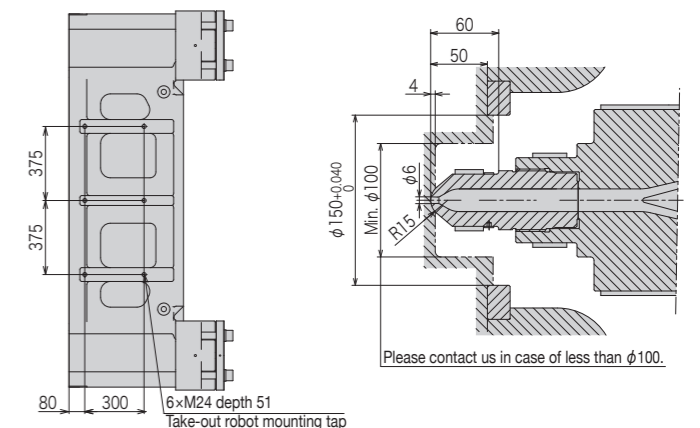

Top of stationary platen

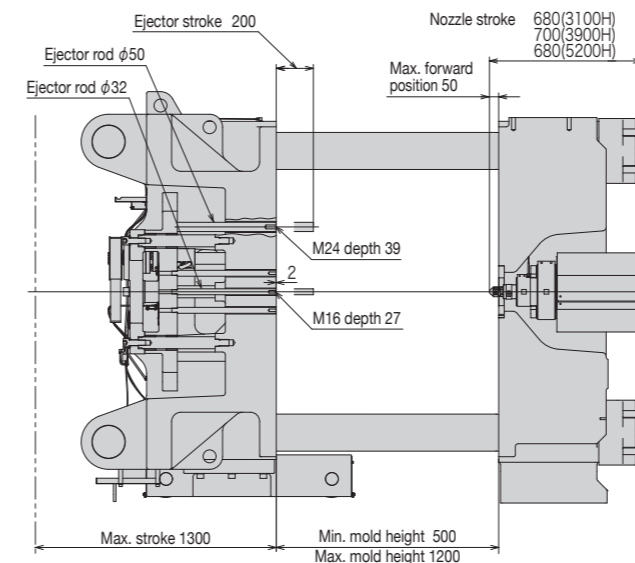

Max. stroke 1300 Min. mold height 500
Max. mold height 1200

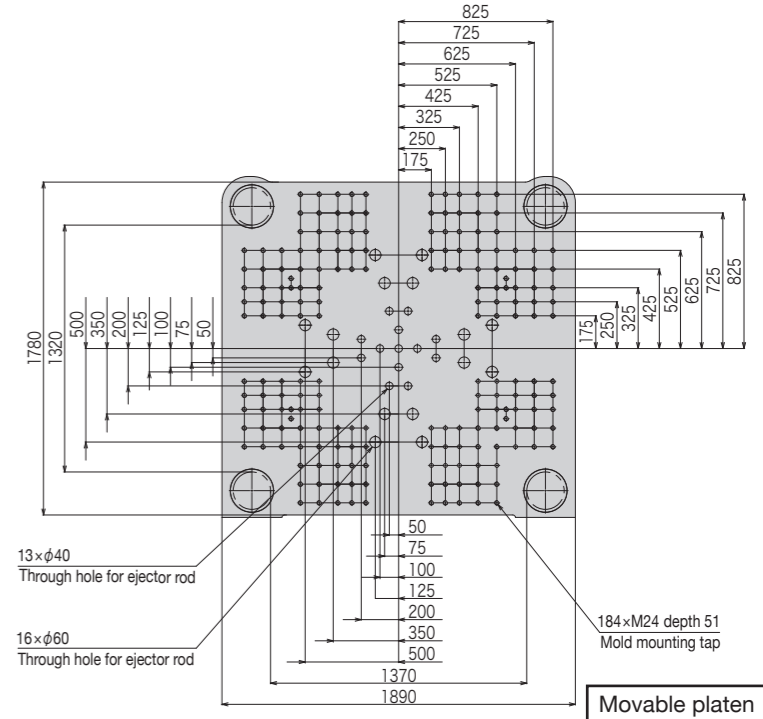

Movable platen

Performance Table

Equipment Dimensions and Mold Related Dimensions

Unit	Item	Model	J1300ADS								
			3900H			5200H			7500H		
Injection Unit	Screw diameter	mm	92	100	110	100	110	120	110	120	130
	Screw stroke	mm	500			550			660		
	Theoretical injection capacity	cm ³	3324	3927	4752	4320	5227	6220	6272	7464	8760
	Injection capacity (GP-PS)	g	3025	3574	4324	3931	4756	5661	5708	6793	7972
	Injection capacity (PP)	g	2426	2867	3469	3153	3816	4541	4579	5449	6395
	Injection pressure (Max.)	MPa(kgf/cm ²)	190(1930)	185(1880)	153(1560)	188(1910)	180(1830)	151(1540)	186(1890)	180(1830)	153(1560)
	Holding pressure (Max.)	MPa(kgf/cm ²)	171(1740)	167(1700)	138(1400)	169(1720)	162(1650)	136(1380)	167(1700)	162(1650)	138(1400)
	Injection speed	mm/s	160			150			130		
	Injection rate	cm ³ /s	1064	1257	1521	1178	1425	1696	1235	1470	1726
	Plasticizing capacity (GP-PS)	kg/h	580	610	660	660	700	720	690	790	790
	Plasticizing capacity (PP)	kg/h	410	430	450	470	500	520	500	570	570
	Screw speed	min ⁻¹	185	170	155	170	155	145	145	145	135
	Nozzle touch force	kN(tf)	70(7.1)			70(7.1)			70(7.1)		
	Nozzle stroke from platen	mm	50								
Type of nozzle		Open nozzle									
Barrel temperature control		Barrel 5, Nozzle 1						Barrel 5, Nozzle 2			
Heater wattage	kW	43.3			52.1			66.3			
Clamping Unit	Mechanism		Double toggle								
	Clamping force	kN(tf)	12700(1300)								
	Daylight opening (Max.)	mm	2800								
	Opening stroke (Max.)	mm	1500								
	Mold height	mm	550 ~ 1300								
	Dry cycle (Euromap6)	s-mm	4.4 - 1050								
	Distance between Tie-bars (H×V)	mm	1520 × 1470								
	Platen size (H×V)	mm	2120 × 2000								
	Locating ring diameter	mm	150								
	Ejector point		29 points								
General	Ejector force	kN(tf)	300(30.6)								
	Ejector stroke	mm	250								
	Machine Weight	t	83			84			88		
Machine Dimensions (L×W×H)	m	11.99 × 3.48 × 3.01			12.36 × 3.48 × 3.01			12.89 × 3.48 × 3.01			

Remarks

- Maximum injection pressure and maximum holding pressure may be restricted due to molding condition.
- The theoretical injection capacity is (cross sectional area of barrel) × (stroke of screw).
- The injection capacity is variable according to the grade of resin, molding conditions and mold.
- The values for plasticizing capacity are based on our standard test conditions.
- PC, HPVC, other engineering plastic, etc., low temperature setting and high speed molding may require a high torque depending on the grade or molding conditions. Please contact us if you plan.

Note

- 1MPa=10.2kgf/cm², 1kN=0.102tf
- Due to continual improvements, specifications are subject to change without notice.
- Actual figures of the specification will vary depending on final machine configuration. Please contact us if you require more specific data.
- Performance specifications are based on theoretical data.

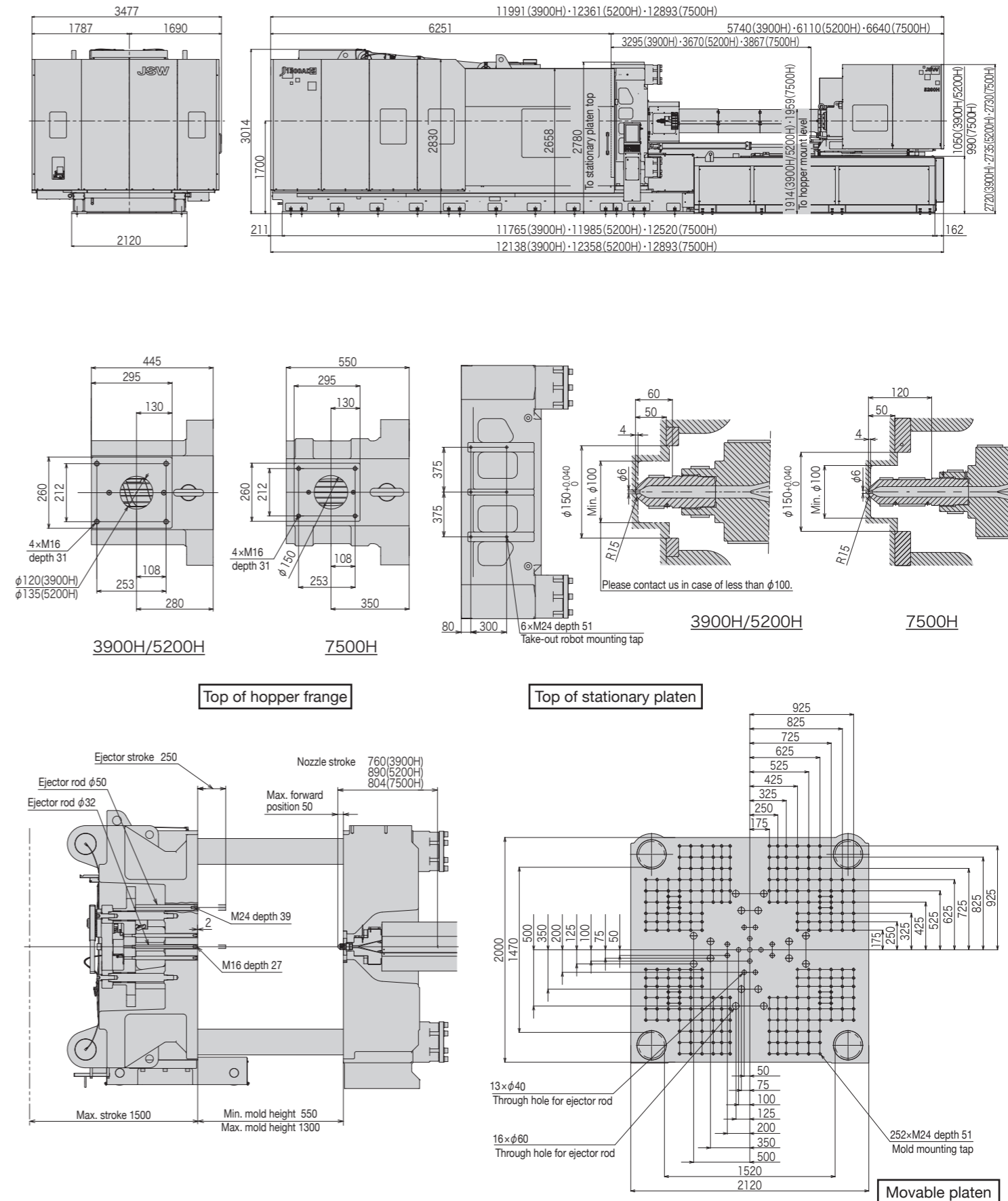

Standard Equipment List

Item			
Injection and Plasticizing Unit	Open nozzle	Note1	
	N2000F barrel		
	Chrome plated screw	Note2	
	Screw Pull-back		
	Purge cover (with limit switch)		
	Injection Unit Swiveling device (with limit switch)	Note3	
	Screw cold start prevention		
	Molding/Purging/Pause temperature select		
	Auto purging circuit		
	Nozzle retract select		
	Injection/Metering programmed control	Injection/Holding pressure:1~6steps(Variable) Metering/Back pressure:1~3steps(Variable)	
	Holding pressure transfer select		
	Holding pressure control select		
	Pull-back select		
	Barrel temperature control (PID/SSR)		
	Nozzle temperature control (PID/SSR)		
	Synchronous temperature rise control		
	Hopper flange temperature control		
	Soft pack servo control		
	HAVC (High Accuracy Volume Control)		
	IWCS (Injection Weight and Cushion Stability) control		
	Reverse seal control		
	Auto grease lubrication		
	Clamping Unit	High performance platen support	
		Low vibration mold open/close	
		Wide platen	
		Flat press platen mechanism (Stationary side/Movable side)	
		Mold open/close and Ejector programmed control	Mold open/close:4 steps(Fixed) Ejector:1~3 steps(Variable)
		Mold protection function	
		Ejector servo motor with brake	
		Mold open/close servo motor with brake	
		Auto mold thickness adjusting device	
		Auto clamp force setting	
		Clamp force display	
Clamping force feedback control			
Ejector plate return confirmation circuit			
Electrical clamping unit safety device			
Robot mounting holes			
Compound action		Screw rotation during mold open/close Eject during mold open Injection during clamp up	
Safety mat (Under mold area) J850ADSW and above		Note4	
Grease free toggle bushing			
Auto grease lubrication			

Note1. 1400H and below are chip types.

Note2. 2300H and above are M3-CL screws.

1400H and below are GP-21 screws.

Note3. 1400H and below are manual.

Note4. J850ADSW and above are standard equipment. (models with tie-bar spacing larger than 1200mm)

J550ADS to J850ADS are optional. (Tie-bar interval smaller than 1200mm)

The safety mat on the top of the steps is optional.

Note5. Commercial USB flash drives can also store molding conditions.

Note6. You can save the controller screen in PNG format and measured values in CSV format.

Note7. Temperature sensor and wiring not included.

Note8. You can select up to 18 display items and alarms from the list below.

(1) Cycle Time (2) Injection Time (3) Metering Time (4) Maximum Injection Pressure (5) Cushion Position

(6) Holding pressure end position (7) Holding pressure transfer pressure (8) Back pressure (9) Metering end position

(10) Injection Start Position (11) Holding Pressure Transfer Position (12) Metering Torque (13) Holding Pressure Transfer Speed

(14) Mold close time (15) Mold open time (16) Clamp force (17) Shift amount (HAVC) (18) End Speed (HAVC)

Note9. Notifies you of component inspection times based on molding conditions.

Item			
Controller	Touch panel 15" TFT color LCD controller		
	300 mold condition storage (Internal memory)	Note5	
	Soft Start molding		
	Self diagnostics function		
	I/O customize function		
	Molding operation assist [J-Assist]		
	Help function		
	Pop up display		
	Manual browsing function		
	Start up safety notice		
	Molding condition memo		
	Clock function		
	Multi language select (English,Chinese,Japanese)		
	USB port x2	Note6	
	Overall setting screen		
	Preheat timer		
	Product takeout robot circuit		
	Attended/Unattended operation select		
	Emergency stop button		
	Safety key		
	Monitor	Actual value display	
		Mold temperature display	Note7
		Injection/Metering waveform monitor	
		Oscilloscope waveform monitor	
		Energy consumption and regeneration monitor	
		Injection/Metering waveform storage	
		barrel temperature monitor	
		Injection pressure monitor (IPM)	
		Statistical graph	
		Production monitor	
		Cumulative operating hour display	
		Cycle monitor	
		Molding condition upper/lower limit monitor	Note8
		Inspection and maintenance guide [J-Support]	Note9
Heater system alarm			
Injection pressure overshoot Alarm			
Grease lubrication Alarm			
Servo fault alarm			
Unreleased clamp alarm			
Position calibration request			
Fault alarm buzz			
Alarm history			
Set value history			
Others	Safety compliance (ISO20430,ISO60204-1)		
	Cooling water closed circuit for feed throat		
	Accessories (maintenance tools and Ejector Rods,etc.)		

Options List

Item			
Injection Unit	Long nozzle		
	Shut off nozzle (Pneumatic type and hydraulic type)		
	Mixing nozzle		
	KC nozzle (Support up to 3100H Φ 92)		
	LSP-2 screw (Abrasion resistant type)		
	Special design screw	M2K screw for optical application HP screw for high dispersion	
	Wide selection of screws & barrels	Note1	
	Barrel insulation cover		
	Barrel blower cooling unit (with insulation or no insulation)		
	Hopper		
	Hopper slide device		
	High speed injection spec.(Up to 3900H)		
	Extended holding pressure time spec.	Note2	
	Long time plasticizing spec.	Note3	
	Electric motor driven injection unit advance/retract		
	Purge shutter		
	Clamping Unit	Daylight extension	
		Mold platen heat insulation board (5 or 10 mm)	Note4
Locating ring			
Air jet			
Core pull devices (Pneumatic type and hydraulic type)		Note5	
Valve gate devices (Pneumatic type and hydraulic type)		Note5	
Coupler joint (hydraulic, Pneumatic)			
Hydraulic power pack			
Ejector gate cutting circuit			
Ejector (One touch type)			
Unscrewing motor circuit			
Auto safety gate open (Operation side)			
Auto safety gate open/close (Operation side/Non Operation side/Both sides)			
Safety mat (Under mold area) J550ADS to J850ADS		Note6	
Safety mat (Top of the steps)			
Safety footplate			
T slot platen			
Mold clamber device (Pneumatic, hydraulic, magnet type)		Note4	
Easy mold clamber			
Toggle type injection compression function Compression:1-6 steps(Variable)			
Forming mold control			
Mechanical clamping unit safety device			

Item		
Electrical Instrumentation and Control	Multi language select (1 language additional)	Note7
	J-WiSe® solution	Note1
	Mold temp display (with mold temp upper/lower limit alarm)	
	Mold temp control device (with mold temp upper/lower limit alarm)	
	Hot runner control circuit	
	Receptacle	Note8
	Multiple injection	
	Flow mold	
	Spear output signal circuit	
	Motion/no-motion select	
Others	Hopper stage	
	Mold cooling water closed circuit (platen/bed)	
	Cooling water failure warning	
	Air pressure alarm	
	Leveling pad for installation	
	Movement prevent anchor bolts	
	Rotary warning light	
	Export specification	Note9
	Designated color	Note10

Note1. Please contact us for detailed specifications.

Note2. High pressure holding capacity for a long time.

Injection speed may be slow.

Note3. Can be plasticized with high torque.

Plasticizing capacity may be reduced.

Note4. When an insulated plate or magnetic clamber is mounted, the nozzle plunge amount must take these thicknesses into account.

Specification values for mold thicknesses have also been changed.

Note5. The hydraulic system requires an increase in the capacity of the hydraulic unit.

Note6. J850ADSW and above are standard equipment.

(models with tie-bar spacing larger than 1200mm)

J550ADS to J850ADS are optional. (Tie-bar interval smaller than 1200mm)

Note7. Japanese, English and Chinese are standard equipment.

Note8. Please specify the power supply voltage and the number of outlets required for ancillary equipment.

Note9. Export specifications must be discussed depending on the destination.

Note10. Designate colors, referring to color samples or Munsell Color Codes.

■ Total power capacity

Machine model	Total power capacity (kVA)	
J550ADS	1400H	51
	2300H	56
	3100H	65
J650ADS	2300H	58
	3100H	67
	3900H	84
J850ADS J850ADSW	3100H	67
	3900H	84
	5200H	90
J1000ADS	3100H	68
	3900H	85
	5200H	90
J1300ADS	3900H	85
	5200H	90
	7500H	102
J1400ADS	3900H	85
	5200H	90
	7500H	102

Note1. Total power capacity does not include external outlets.

2. We recommend that the rated interrupting current of the main power supply breaker is more than 25kA at AC400V/460V.

■ Cooling water capacity for barrel temperature control

Injection unit	Cooling water capacity for barrel temperature control (m ³ /h)
1400H	0.6
2300H	1.2
3100H	
3900H	1.6
5200H	
7500H	

Note. The above figures do not include the required quantity of water for the mold temperature controller.

■ Hydraulic oil capacity

Machine model	Hydraulic oil capacity (L)
J550ADS	30
J650ADS	
J850ADS	
J850ADSW	
J1000ADS	
J1300ADS	
J1400ADS	